

Absolute encoders – multiturn

Standard electronic multiturn, magnetic	Sendix M5868 (shaft)	CANopen
--	-----------------------------	----------------



The Sendix M58 with Energy Harvesting Technology is an electronic multiturn encoder without gear and without battery – in the standard format with 58 mm flange.

High robustness and high resolution make this encoder the ideal device for use in demanding applications.



Safety-Lockplus™	High rotational speed	Temperature range -40°... +85°C	High protection level IP	High shaft load capacity	Shock / vibration resistant	Reverse polarity protection	Energy Harvesting

Highest robustness

- Sturdy bearing construction in Safety-Lockplus™ design for particularly high resistance.
- Extra large bearings.
- Mechanically protected shaft seal.
- Wide temperature range -40 °C ... +85 °C.
- Without gear and without battery, thanks to the Energy Harvesting technology.

Up-to-the-minute fieldbus performance

- LSS services for configuration of the node address and baud rate.
- Variable PDO mapping in the memory.
- Universal scaling function.
- Configuration management (bootloader).

Order code	8.M5868	.XX2X.	21	22
Shaft version	Type	a b c d	e	

- a** Version
3 = clamping flange, IP65, ø 58 mm [2.28"]
4 = synchro flange, IP65, ø 58 mm [2.28"]
- b** Shaft (ø x L), with flat
1 = ø 6 x 12.5 mm [0.24 x 0.49"]
5 = ø 10 x 20 mm [0.39 x 0.79"]
- c** Interface / supply voltage
2 = CANopen DS301 V4.2 / 10 ... 30 V DC

- d** Type of connection
2 = radial cable, 1 m [3.28'] PVC
B = radial cable, special length PVC *)
4 = radial M12 connector, 5-pin
- *) Available special lengths (connection types B):
2, 3, 5, 8, 10, 15 m [5.56, 9.84, 16.40, 26.25, 32.80, 49.21']
order code expansion .XXXX = length in dm
ex.: 8.M5868.312B.2122.0030 (for cable length 3 m)

- e** Fieldbus profile
21 = CANopen
- Optional on request*
- Ex 2/22 (only for connection type 4)

Absolute encoders – multiturn

Standard electronic multiturn, magnetic		Sendix M5868 (shaft)	CANopen
Mounting accessory for shaft encoders			Order no.
Coupling	Bellows coupling ø 19 mm [0.75"] for shaft 10 mm [0.39"]		8.0000.1102.1010
Cables and connectors			Order no.
Preassembled cables	M12 female connector with coupling nut, 5-pin, A coded, straight single ended 5 m [16.40'] PVC cable	Bus in	05.00.6091.A211.005M
	M12 female connector with coupling nut, 5-pin, A coded, straight Deutsch connector DT04, male contacts, 6-pin, straight 1 m [3.28'] PVC cable	Bus in	05.00.6091.22C7.001M
Connectors	M12 female connector with coupling nut, 5-pin, A coded, straight (metal)	Bus in	8.0000.5116.0000

Further Kübler accessories can be found at: kuebler.com/accessories
 Further Kübler cables and connectors can be found at: kuebler.com/connection-technology

Technical data

Mechanical characteristics	
Maximum speed	4000 min ⁻¹ 2000 min ⁻¹ (continuous)
Starting torque at 20 °C [68 °F]	< 0.01 Nm
Shaft load capacity	radial 80 N axial 40 N
Weight	approx. 280 g [9.88 oz]
Protection acc. to EN 60529/DIN 40050-9	IP65
Working temperature range	-40 °C ... +85 °C [-40 °F ... +185 °F]
Materials	shaft V2A flange aluminum housing zinc die-cast cable PVC
Shock resistance acc. to EN 60068-2-27	5000 m/s ² , 4 ms
Vibration resistance acc. to EN 60068-2-6	300 m/s ² , 10 ... 2000 Hz

Electrical characteristics	
Supply voltage	10 ... 30 V DC
Current consumption (no load)	max. 30 mA
Reverse polarity protection of the supply voltage	yes
Short-circuit proof outputs	yes ¹⁾

Approvals	
E1 compliant in accordance with	ECE guideline
UL compliant in accordance with	File no. E224618
CE compliant in accordance with	EMC Directive 2014/30/EU RoHS Directive 2011/65/EU ATEX Directive 2014/34/EU (for Ex 2/22 variants)
UKCA compliant in accordance with	EMC Regulations S.I. 2016/1091 RoHS Regulations S.I. 2012/3032 UKEX Regulations S.I. 2016/1107 (for Ex 2/22 variants)

Interface characteristics CANopen	
Resolution singleturn (MUR)	scalable 1 ... 16 384 (14 bit) default 16 384 (14 bit)
Number of revolutions (NDR)	1 ... 536 870 912 (29 bit) scalable only via the total resolution
Total resolution (TMR)	raw value max. 8 796 093 022 208 (43 bit) scalable 1 ... 4 294 967 296 (32 bit) default 4 294 967 296 (32 bit)
Absolute accuracy ³⁾	±1°
Repeat accuracy	±0.2°
Interface	CAN high-speed acc. to ISO 11898, Basic- and Full-CAN, CAN specification 2.0 B
Protocol	CANopen profile DS406 V4.0 with manufacturer-specific add-ons, LSS-Service, bootloader
Power-ON time	< 1200 ms
SDO timeout	< 1000 ms
Baud rate	10 ... 1000 kbit/s software configurable
Node address	1 ... 127 software configurable
Termination	software configurable
LSS protocol	CIA LSS protocol DS305, global command support for node address and baud rate, selective commands via attributes of the identity object
Bootloader	configuration management CIA DS 302-3

1) Short circuit proof to 0 V or to output when supply voltage correctly applied.
 2) Over the whole temperature range.

Absolute encoders – multiturn

Standard electronic multiturn, magnetic	Sendix M5868 (shaft)	CANopen
--	-----------------------------	----------------

General information about CANopen

The CANopen encoders support the latest CANopen communication profile according to DS301 V4.02. In addition, device-specific profiles like the encoder profile DS406 V3.2, DS305 (LSS) and DS302 (Bootloader) are available.

The following operating modes may be selected: Polled Mode, Cyclic Mode, Sync Mode. Moreover, scale factors, preset values, limit switch values and many other additional parameters can be programmed via the CANbus. When switching the device on, all parameters, which have been saved on a flash memory to protect them against power failure, are loaded again.

The following output values may be combined in a freely variable way as PDO (PDO mapping): **position, speed, acceleration** as well as the **status of the working area**.

The encoders are available with a connector or a cable connection.

The device address and baud rate can be set/modified by means of the software.

The two-color LED located on the back indicates the operating or fault status of the CAN-bus, as well as the status of the internal diagnostics.

CANbus connection

The CANopen encoders are equipped with a bus trunk line in various lengths or a M12 connector and can be terminated in the device.

The devices do not have an integrated T-coupler nor they are looped internally and must therefore only be used as end devices.

LSS layer setting services DS305 V2.0

- Global command support for node ID and baud rate configuration.
- Selective protocol via identity object (1018h).

CANopen communication profile DS301 V4.2

Among others, the following functionality is integrated. (Class C2 functionality):

- NMT Slave.
- Heartbeat Protocol.
- Identity Object.
- Error Behavior Object.
- Variable PDO Mapping self-start programmable (Power on to operational), 3 Sending PDO's.
- Node address, baud rate and CANbus / programmable termination.

CANopen encoder profile DS406 V4.0

The following parameters can be programmed:

- Event mode, start optional.
- 1 work area with upper and lower limit and the corresponding output states.
- Variable PDO mapping for position, speed, work area status, error and acceleration.
- Extended failure management for position sensing.
- User interface with visual display of bus and failure status 1 LED two colors.
- Customer-specific protocol.
- "Watchdog controlled" device.

Bootloader functionality DS302-3

Configuration Management:

- Program download.
- Program start.
- Program erase.

Terminal assignment

Interface	Type of connection	Cable (isolate unused wires individually before initial start-up)					
2	2, B	Signal:	+V	0 V	CAN_GND	CAN_H	CAN_L
		Cable color:	BN	WH	GY	GN	YE
Interface	Type of connection	M12 connector, 5-pin					
2	4	Signal:	+V	0 V	CAN_GND	CAN_H	CAN_L
		Pin:	2	3	1	4	5

Top view of mating side, male contact base

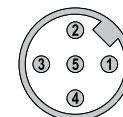

M12 connector, 5-pin

Absolute encoders – multiturn

Standard electronic multiturn, magnetic	Sendix M5868 (shaft)	CANopen
--	-----------------------------	----------------

Dimensions

Dimensions in mm [inch]

Clamping flange, ø 58 [2.28]

Flange type 3

- 1 3 x M4
- 2 3 x M3

D	Fit	L
6 [0.24]	h7	12.5 [0.49]
10 [0.39]	h7	20 [0.79]

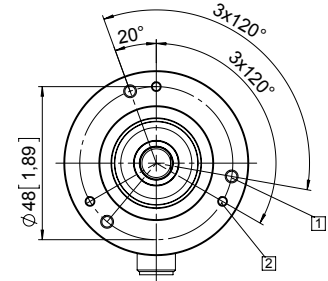
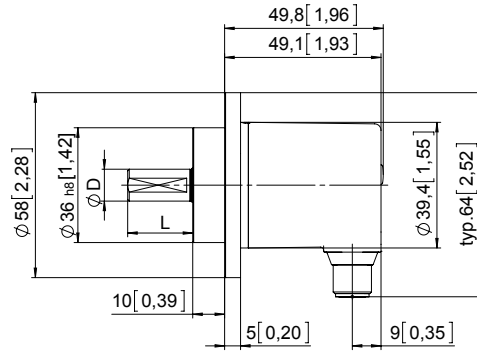

Synchro flange, ø 58 [2.28]

Flange type 4

- 1 3 x M4, 10 [0.39] deep

D	Fit	L
6 [0.24]	h7	12.5 [0.49]
10 [0.39]	h7	20 [0.79]

